

Poly-carbonmonofluoride Lithium Batteries: Individual Specifications

BR-2/3A

■ Dimensions(mm)

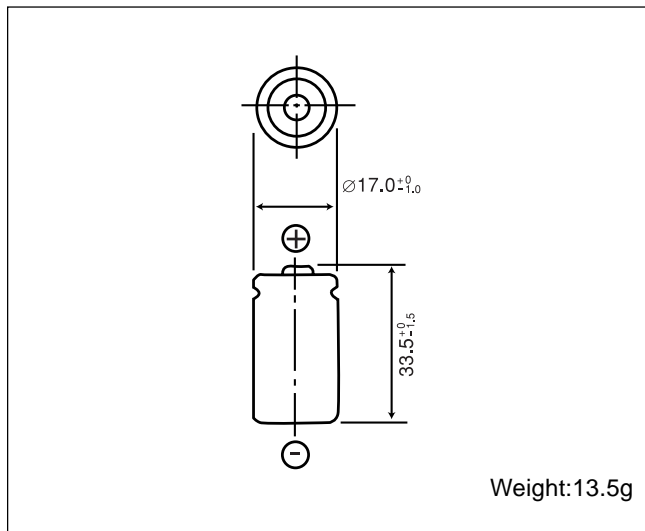

■ Specification

Nominal voltage(V)	3
Nominal capacity(mAh)	1,200
Continuous drain(mA)	2.5
Operating temperature(°C)	-40 ~ +85

■ Temperature Characteristics

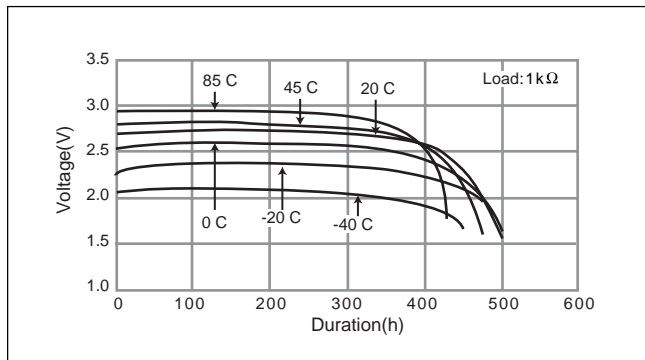

■ Operating voltage vs. Discharge current(voltage at 50% discharge depth)

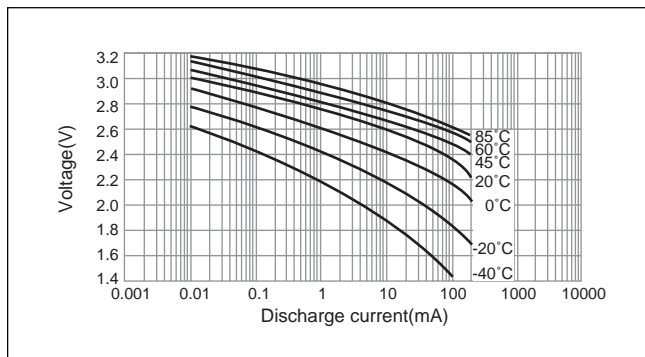

BR-2/3AG

■ Dimensions(mm)

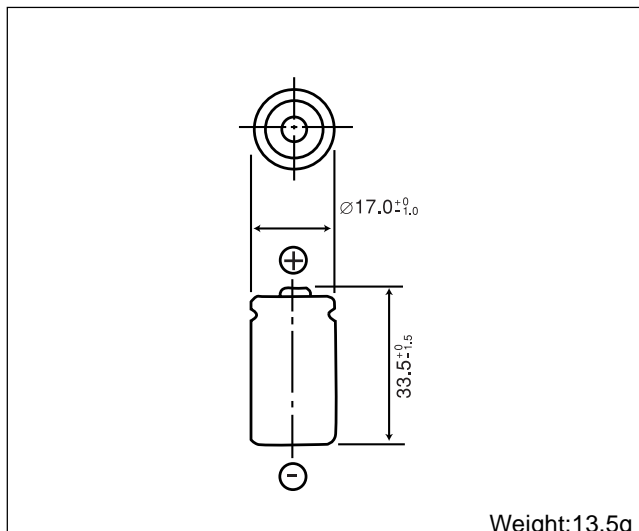

■ Specification

Nominal voltage (V)	3
Nominal capacity (mAh)	1,450
Continuous standard load (mA)	2.5
Operating temperature (C)	-40 ~ +85

■ Temperature Characteristics

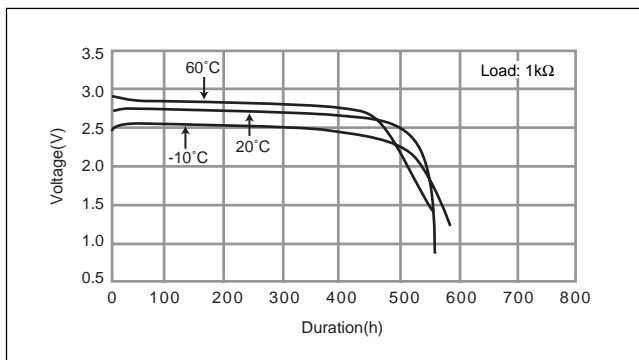

■ Operating voltage vs. Discharge current(voltage at 50% discharge depth)

